

UNCONTROLLED DOCUMENT

PART NUMBER  
SSI-LXH55SRD

REV.  
C

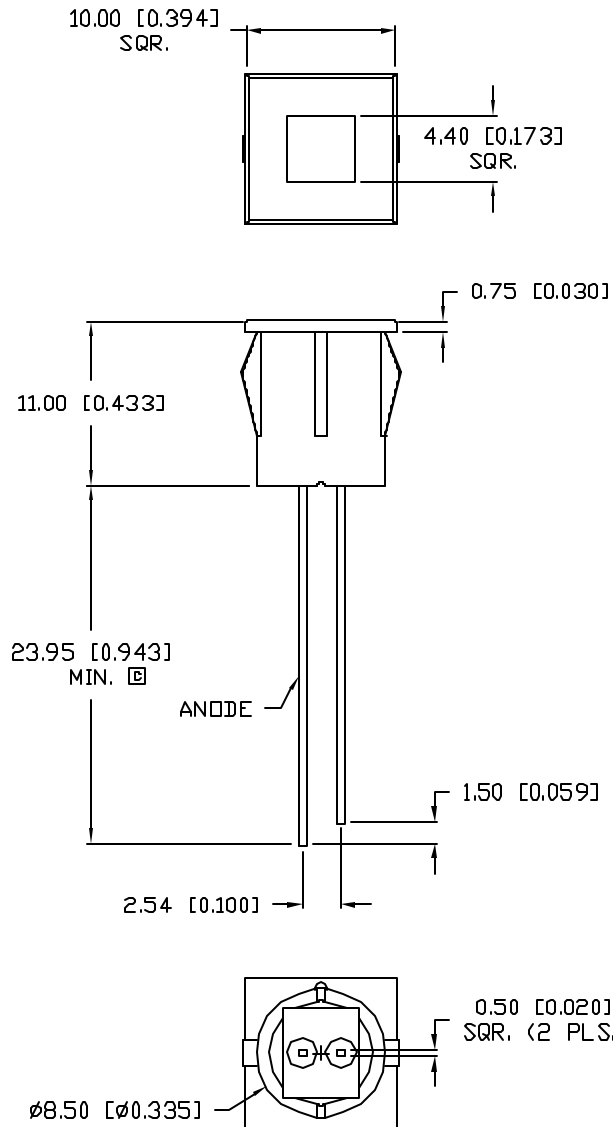

REV.	E.C.N. NUMBER AND REVISION COMMENTS	DATE
A	UPDATED SAFE OPER SPECS.	9.8.94
B	E.C.N. #10185 & #10113.	6.10.96
C	E.C.N. #10667.	10.2.00

ELECTRO-OPTICAL CHARACTERISTICS  $T_A=25^\circ\text{C}$   $I_f=20\text{mA}$

PARAMETER	MIN	TYP	MAX	UNITS	TEST COND
PEAK WAVELENGTH		660		nm	
FORWARD VOLTAGE		1.8	2.2	$V_f$	
REVERSE VOLTAGE	4.0			$V_r$	$I_f=100\mu\text{A}$
AXIAL INTENSITY		20		mcd	$I_f=20\text{mA}$
VIEWING ANGLE		80		2x theta	
EMITTED COLOR:	RED				
EPOXY LENS FINISH:	RED DIFFUSED				

LIMITS OF SAFE OPERATION AT  $25^\circ\text{C}$

PARAMETER	MAX	UNITS
PEAK FORWARD CURRENT*	150	mA
STEADY CURRENT	30	mA
POWER DISSIPATION	100	mW
DERATE FROM $25^\circ\text{C}$	-1.2	mW/ $^\circ\text{C}$
OPERATING, STORAGE TEMP.	-40 TO +85	$^\circ\text{C}$
SOLDERING TEMP.	+260	$^\circ\text{C}$
2.0mm FROM BODY		3 SEC. MAX

\*  $t < 10\mu\text{s}$

NOTES:

- SSH-LXH55, BLACK NYLON HOLDER.
- SSL-LX6573SRD, RED LED.
- PANEL CUT OUT: 8.45mm [0.345] SQR.

\*UNLESS OTHERWISE SPECIFIED TOLERANCES PER DECIMAL PRECISION ARE: X=±1 (±0.039), XX=±0.5 (±0.020), XXX=±0.25 (±0.010), XXXX=±0.127 (±0.005). LEAD SIZE=±0.05 (±0.002), LEAD LENGTH=±0.75 (±0.030), MIN.=<sup>+DECIMAL PRECISION</sup>-0.00 MAX.=<sup>+0.00</sup>-DECIMAL PRECISION

UNCONTROLLED DOCUMENT

REV. C	PART NUMBER SSI-LXH55SRD
5mm x 5mm 660nm SUPER RED LED PANEL INDICATOR, RED DIFFUSED LENS.	

CONFIDENTIAL INFORMATION  
THE INFORMATION CONTAINED IN THIS DOCUMENT IS THE PROPERTY OF LUMEX INC. EXCEPT AS SPECIFICALLY AUTHORIZED IN WRITING BY LUMEX INC, THE HOLDER OF THIS DOCUMENT SHALL KEEP ALL INFORMATION CONTAINED HEREIN CONFIDENTIAL AND SHALL PROTECT SAME IN WHOLE OR IN PART FROM DISCLOSURE AND DISSEMINATION TO ALL THIRD PARTIES.

RELIABILITY NOTE  
OUR MANY YEARS OF EXPERIENCE DATA ACCUMULATION INDICATE THAT SOLDER HEAT IS A MAJOR CAUSE OF EARLY AND FUTURE FAILURE. PLEASE PAY ATTENTION TO YOUR SOLDERING PROCESS.



290 E. HELEN ROAD  
PALATINE, IL 60067-6976  
PHONE: +1.847.359.2790  
US WEB: www.lumex.com  
TW WEB: www.lumex.com.tw

DRAWN BY: KS/BC	CHECKED BY:	APPROVED BY:	DATE: 7.6.93
			PAGE: 1 OF 1
			SCALE: N/A